



Surface Mount General Purpose Silicon Rectifiers

Reverse Voltage - 2000 V

Forward Current - 1 A

FEATURES

- For surface mounted applications
- Low profile package
- Glass Passivated Chip Junction
- Easy to pick and place
- Lead free in comply with EU RoHS 2011/65/EU directives

MECHANICAL DATA

- Case: SOD-123FL
- Terminals: Solderable per MIL-STD-750, Method 2026
- Approx. Weight: 15mg / 0.00053oz

PINNING

PIN	DESCRIPTION
1	Cathode
2	Anode

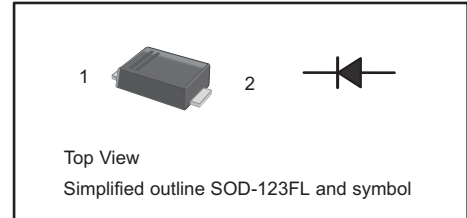

Maximum Ratings and Electrical characteristics

Ratings at 25 °C ambient temperature unless otherwise specified.

Single phase half-wave 60 Hz, resistive or inductive load, for capacitive load current derate by 20 %.

Parameter	Symbols	A20	Units
Maximum Repetitive Peak Reverse Voltage	V_{RRM}	2000	V
Maximum RMS voltage	V_{RMS}	1400	V
Maximum DC Blocking Voltage	V_{DC}	2000	V
Maximum Average Forward Rectified Current@ Fig.1	$I_{F(AV)}$	1	A
Peak Forward Surge Current,8.3ms Single Half Sine-wave Superimposed on Rated Load (JEDEC method)	I_{FSM}	30	A
Peak Forward Surge Current,1ms Single Half Sine-wave Superimposed on Rated Load (JEDEC method)	I_{FSM}	60	A
I^2t Rating for fusing($3ms \leq t \leq 8.3ms$)	I^2t	3.7	A ² S
Maximum Instantaneous Forward Voltage at 1 A	V_F	1.1	V
Maximum DC Reverse Current at Rated DC Blocking Voltage	I_R	5 50	μ A
Typical Junction Capacitance ⁽¹⁾	C_j	8	pF
Typical Thermal Resistance ⁽²⁾	$R_{\theta JA}$ $R_{\theta JC}$ $R_{\theta JL}$	105 25 32	°C/W
Operating and Storage Temperature Range	T_j, T_{stg}	-55 ~ +150	°C

(1) Measured at 1MHz and applied reverse voltage of 4 V D.C.

(2) P.C.B. mounted with 0.2" X 0.2" (5 X 5 mm) copper pad areas.



Fig.1 Forward Current Derating Curve

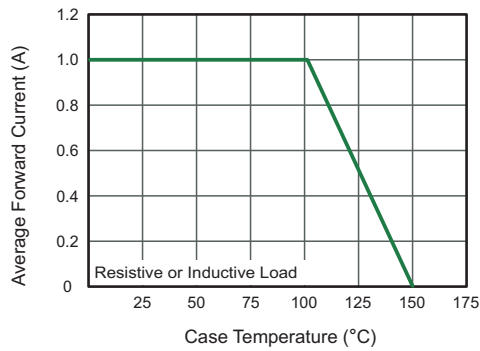

Fig.2 Typical Instantaneous Reverse Characteristics

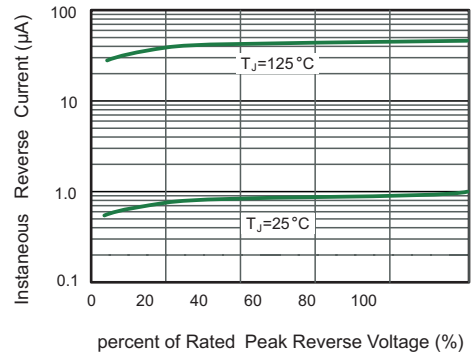

Fig.3 Typical Forward Characteristic

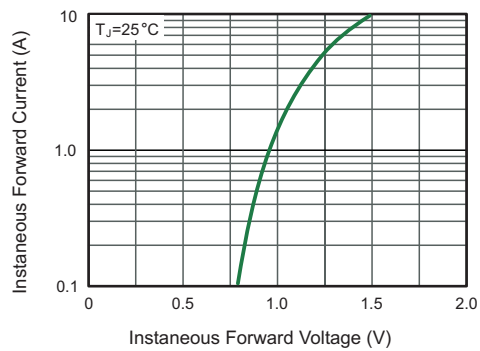

Fig.4 Typical Junction Capacitance

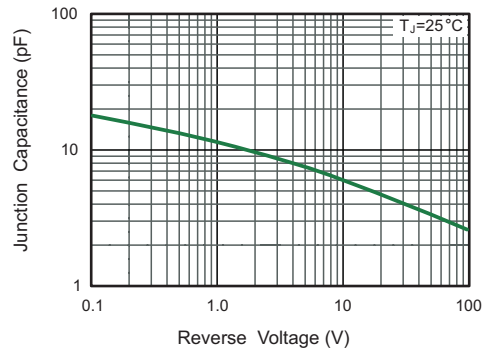
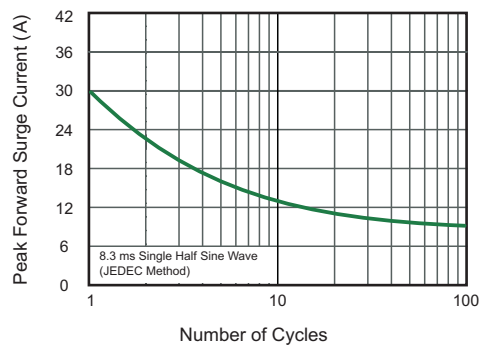

Fig.5 Maximum Non-Repetitive Peak Forward Surge Current





PACKAGE OUTLINE

Plastic surface mounted package; 2 leads

SOD-123FL

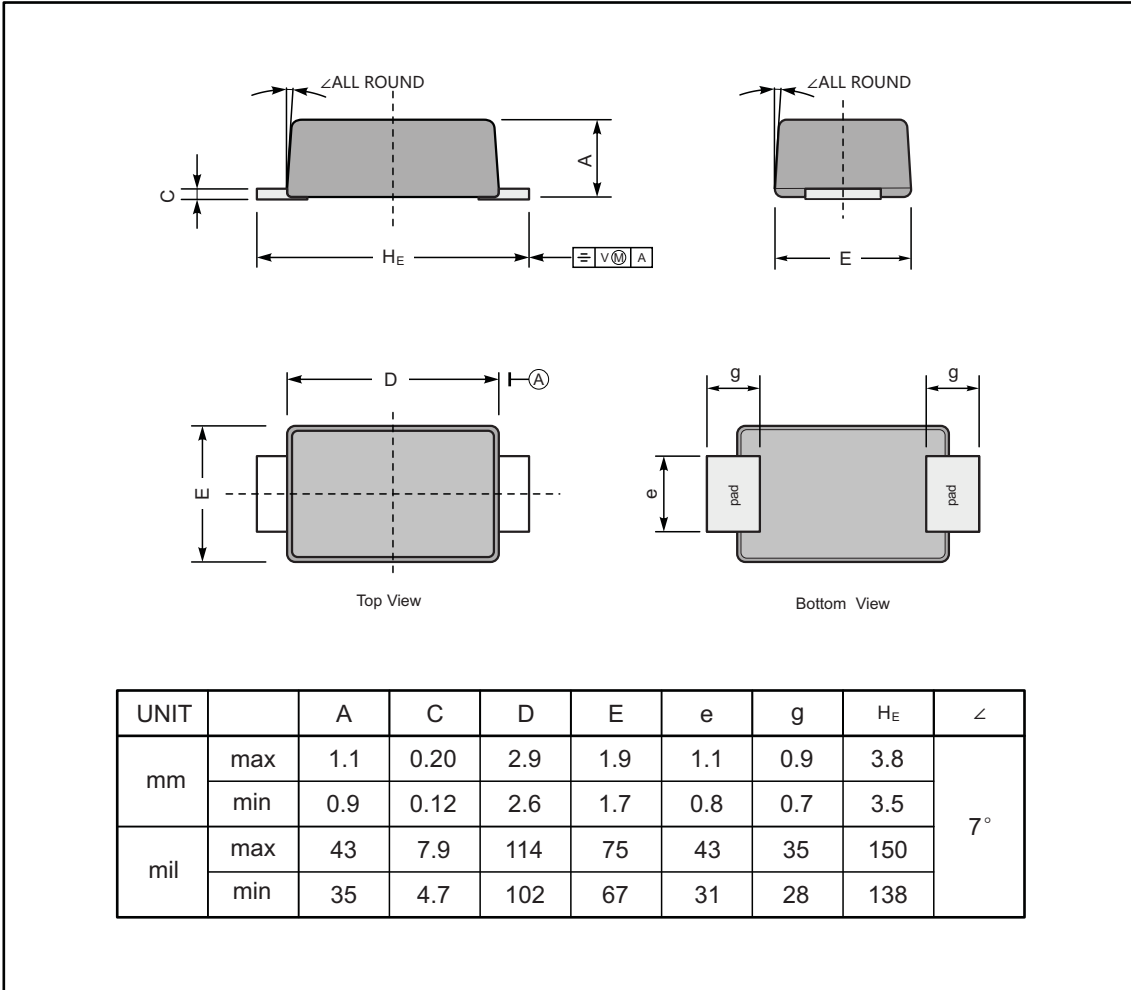

The recommended mounting pad size

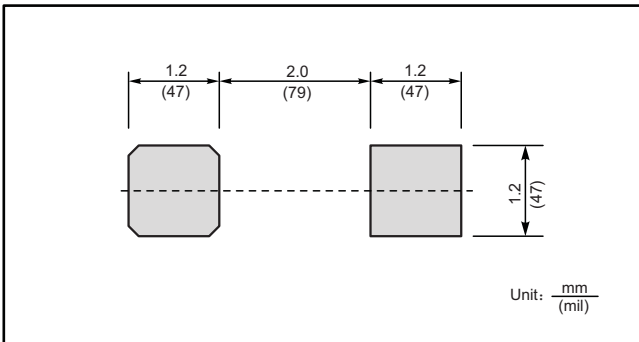

Marking

Type number	Marking code
A20	A20



Important Notice and Disclaimer

Jingdao Microelectronics reserves the right to make changes to this document and its products and specifications at any time without notice.

Customers should obtain and confirm the latest product information and specifications before final design, purchase or use.

Jingdao Microelectronics makes no warranty, representation or guarantee regarding the suitability of its products for any particular purpose, nor does Jingdao Microelectronics assume any liability for application assistance or customer product design.

Jingdao Microelectronics does not warrant or accept any liability with products which are purchased or used for any unintended or unauthorized application.

No license is granted by implication or otherwise under any intellectual property rights of Jingdao Microelectronics.

Jingdao Microelectronics products are not authorized for use as critical components in life support devices or systems without express written approval of Jingdao Microelectronics.